

हमारा विश्वास... हर एक विद्यार्थी है खास

**JEE
MAIN
Sept.
2020**

QUESTION PAPER WITH SOLUTION

PHYSICS _ 2 Sep. _ SHIFT - 1



MOTION™

H.O. : 394, Rajeev Gandhi Nagar, Kota
www.motion.ac.in | ✉: info@motion.ac.in

हमारा विश्वास... हर एक विद्यार्थी है खास

Q.1 The mass density of a spherical galaxy K varies as $\frac{K}{r}$ over a large distance ' r ' from its centre. In that region, a small star is in a circular orbit of radius R . Then the period of revolution, T depends on R as:

- (1) $T^2 \propto R$ (2) $T^2 \propto R^3$ (3) $T^2 \propto \frac{1}{R^3}$ (4) $T \propto R$

Sol. (1)

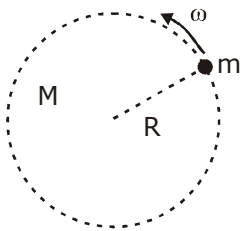

$$\text{Mass of galaxy} = \int_0^R \rho dv$$

$$= \int_0^R \frac{k}{r} 4\pi r^2 dr$$

$$= 4\pi k \int_0^R r dr$$

$$M = \frac{4\pi k R^2}{2} = k_1 R^2$$

$$F = m\omega^2 R$$

$$\frac{GMm}{R^2} = m\omega^2 R$$

$$\frac{Gk_1 R^2}{R^2} = \omega^2 R$$

$$\therefore \omega^2 = \frac{k_2}{R}$$

$$\omega = \sqrt{\frac{k_2}{R}}$$

$$T = \frac{2\pi}{\omega} = 2\pi \sqrt{\frac{R}{k_2}}$$

$$T = k_3 \sqrt{R}$$

$$T^2 \propto R$$

CRASH COURSE
FOR JEE ADVANCED 2020

FREE Online Lectures Available on [YouTube](#)

Go Premium at ₹ 1100

- ◆ Doubt Support ◆ Advanced Level Test Access
- ◆ Live Test Paper Discussion ◆ Final Revision Exercises

Start Date: **07 Sept. 2020**

Q.2 An amplitude modulated wave is represented by the expression $v_m = 5(1 + 0.6 \cos 6280t) \sin(211 \times 10^4 t)$ volts. The minimum and maximum amplitudes of the amplitude modulated wave are, respectively :

- (1) $\frac{3}{2}$ V, 5V (2) 5V, 8V (3) 3V, 5V (4) $\frac{5}{2}$ V, 8V

Sol. (4)

$$\frac{A_m}{A_c} = 0.6$$

$$= (5 + 3 \cos 6280t) \sin(211 \times 10^4 t)$$

maximum Amp. = $5 + 3 = 8$ V

minimum Amp. = $5 - 3 = 2$ V

from the given option nearest value of minimum Amplitude = $\frac{5}{2}$ V

Q.3 A spherical mirror is obtained as shown in the figure from a hollow glass sphere. If an object is positioned in front of the minor, what will be the nature and magnification of the image of the object ? (Figure drawn as schematic and not to scale)

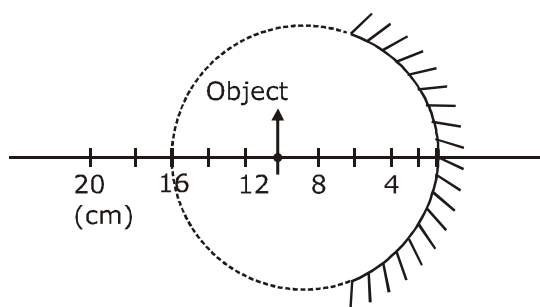

- (1) Erect, virtual and unmagnified (2) Inverted, real and magnified
 (3) Erect, virtual and magnified (4) Inverted, real and unmagnified

Sol. (4)

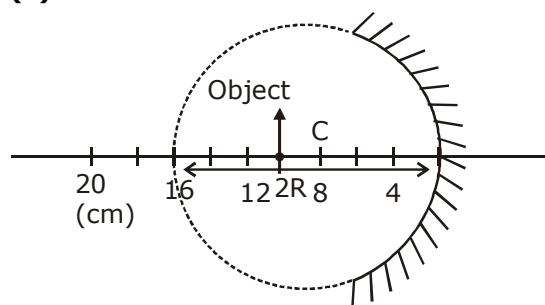

\therefore beyond C i.e. $-\infty < u < C$
 \therefore real, inverted
 and unmagnified

हमारा विश्वास... हर एक विद्यार्थी है खास

- Q.4** A cylindrical vessel containing a liquid is rotated about its axis so that the liquid rises at its sides as shown in the figure. The radius of vessel is 5 cm and the angular speed of rotation is ω rad s^{-1} . The difference in the height, h (in cm) of liquid at the centre of vessel and at the side will be :

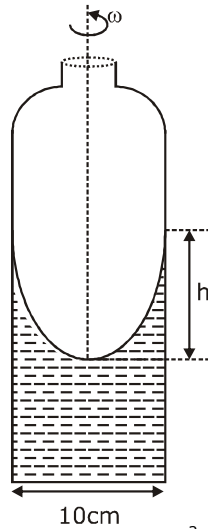

- Sol.** (1) $\frac{5\omega^2}{2g}$ (2) $\frac{2\omega^2}{25g}$ (3) $\frac{25\omega^2}{2g}$ (4) $\frac{2\omega^2}{5g}$
(3)

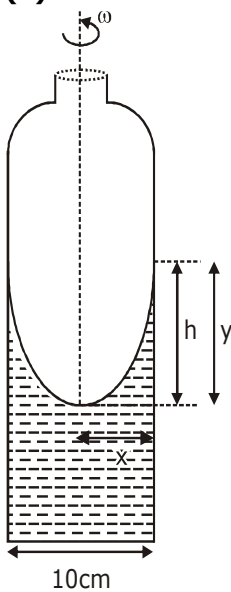

$$y = \frac{\omega^2 x^2}{2g}$$

at $x = 5\text{cm}$, $y = h$

$$h = \frac{\omega^2 (5)^2}{2g} = \frac{25\omega^2}{2g}$$

CRASH COURSE
FOR JEE ADVANCED 2020

FREE Online Lectures Available on **YouTube**

Go Premium at ₹ 1100

- ◆ Doubt Support ◆ Advanced Level Test Access
- ◆ Live Test Paper Discussion ◆ Final Revision Exercises

Start Date: **07 Sept. 2020**

Q.5 If speed V , area A and force F are chosen as fundamental units, then the dimension of Young's modulus will be

- (1) FA^2V^{-3} (2) FA^2V^{-2} (3) $FA^{-1}V^0$ (4) FA^2V^{-1}

Sol. (3)

$$Y = k [F]^x [A]^y [V]^z$$

$$[ML^{-1}T^{-2}] = [MLT^{-2}]^x [L^2]^y [LT^{-1}]^z$$

$$[ML^{-1}T^{-2}] = [M^x L^{x+2y+z} T^{-2x-z}]$$

$$x = 1, -2x - z = -2, x + 2y + z = -1$$

$$\Rightarrow z = 0$$

$$\Rightarrow y = -1$$

Q.6 A bead of mass m stays at point $P(a, b)$ on a wire bent in the shape of a parabola $y = 4Cx^2$ and rotating with angular speed ω (see figure). The value of ω is (neglect friction):

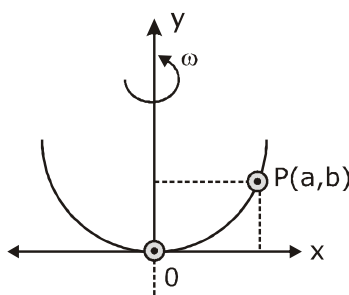

- (1) $\sqrt{\frac{2g}{C}}$ (2) $2\sqrt{gC}$ (3) $\sqrt{\frac{2gC}{ab}}$ (4) $2\sqrt{2gC}$

Sol. (4)

$$y = 4cx^2$$

$$\frac{dy}{dx} = 8cx$$

$$\tan \theta = \frac{m\omega^2 a}{mg}$$

$$\tan \theta = \frac{dy}{dx} = 8cx$$

$$8cx = \frac{\omega^2 a}{g}$$

$$(x = a), 8ca = \frac{\omega^2 a}{g}$$

$$\sqrt{8cg} = \omega$$

$$2\sqrt{2gC} = \omega$$

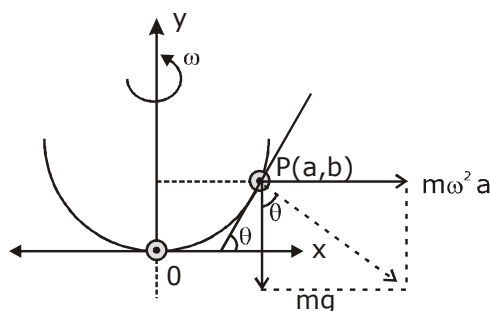

हमारा विश्वास... हर एक विद्यार्थी है खास

- Q.7** Magnetic materials used for making permanent magnets (P) and magnets in a transformer (T) have different properties of the following, which property best matches for the type of magnet required ?
 (1) P : Small retentivity, large coercivity (2) P : Large retentivity, large coercivity
 (3) T : Large retentivity, large coercivity (4) T : Large retentivity, small coercivity

Sol. (2)

Permanent magnet must retain for long use and should not be easily demagnetised.

- Q. 8** Interference fringes are observed on a screen by illuminating two thin slits 1 mm apart with a light source ($\lambda = 632.8 \text{ nm}$). The distance between the screen and the slits is 100 cm. If a bright fringe is observed on screen at a distance of 1.27 mm from the central bright fringe, then the path difference between the waves, which are reaching this point from the slits is close to :
 (1) $2.05 \mu\text{m}$ (2) 2.87 nm (3) 2 nm (4) $1.27 \mu\text{m}$

Sol. (4)

given, $d = 1\text{mm}$

$\lambda = 632.8 \text{ nm}$

$D = 100\text{cm}$

$y = 1.27 \text{ mm}$

$$\Delta x = d \sin \theta$$

$$\because (\theta = \text{small})$$

$$\Delta x = d \tan \theta$$

$$\Delta x = \frac{dy}{D} = \frac{1 \times 10^{-3} \times 1.27 \times 10^{-3}}{100 \times 10^{-2}}$$

$$= 1.27 \times 10^{-6} \text{ m}$$

$$= 1.27 \mu\text{m}$$

- Q.9** A gas mixture consists of 3 moles of oxygen and 5 moles of argon at temperature T. Assuming the gases to be ideal and the oxygen bond to be rigid, the total internal energy (in units of RT) of the mixture is:

(1) 11

(2) 13

(3) 15

(4) 20

Sol. (3)

$$U = n_1 C_{v_1} T + n_2 C_{v_2} T$$

$$= 3 \times \frac{5}{2} RT + 5 \times \frac{3}{2} RT$$

$$= \frac{30}{2} RT = 15RT$$

CRASH COURSE
FOR JEE ADVANCED 2020

FREE Online Lectures Available on  YouTube

Go Premium at ₹ 1100

◆ Doubt Support ◆ Advanced Level Test Access
 ◆ Live Test Paper Discussion ◆ Final Revision Exercises

Start Date: **07 Sept. 2020**

Q. 10 A plane electromagnetic wave, has frequency of 2.0×10^{10} Hz and its energy density is 1.02×10^{-8} J/m³ in vacuum. The amplitude of the magnetic field of the wave is close

$$\left(\frac{1}{4\pi\epsilon_0} = 9 \times 10^9 \frac{\text{Nm}^2}{\text{C}^2} \text{ and speed of light} = 3 \times 10^8 \text{ ms}^{-1} \right);$$

- (1) 160 nT (2) 150 nT (3) 180 nT (4) 190 nT

Sol. (1)

$$\text{energy density} = \frac{B_0^2}{2\mu_0} \quad \dots(1)$$

$$\& C = \frac{1}{\sqrt{\mu_0 \epsilon_0}} \quad \dots(2)$$

$$\mu_0 = \frac{1}{C^2 \epsilon_0}$$

$$B = \sqrt{U \times 2\mu_0}$$

$$= \sqrt{1.02 \times 10^{-8} \times 2 \times \frac{1}{9 \times 10^{16}} 4\pi \times 9 \times 10^9}$$

$$= \sqrt{25.62 \times 10^{-15}}$$

$$\cong \sqrt{25600 \times 10^{-18}}$$

$$\cong 160 \times 10^{-9}$$

$$= 160\text{nT}$$

Q. 11 Consider four conducting materials copper, tungsten, mercury and aluminium with resistivity ρ_C, ρ_T, ρ_m and ρ_A respectively. Then :

- (1) $\rho_C > \rho_A > \rho_T$ (2) $\rho_A > \rho_m > \rho_C$ (3) $\rho_A > \rho_T > \rho_C$ (4) $\rho_m > \rho_A > \rho_C$

Sol. (4)

(Theoretical concept)

Q.12 A beam of protons with speed 4×10^5 ms⁻¹ enters a uniform magnetic field of 0.3 T at an angle of 60° to the magnetic field. The pitch of the resulting helical path of protons is close to : (Mass of the proton = 1.67×10^{-27} kg, charge of the proton = 1.69×10^{-19} C)

- (1) 4 cm (2) 2 cm (3) 12 cm (4) 5 cm

CRASH COURSE
FOR JEE ADVANCED 2020

FREE Online Lectures Available on YouTube

Go Premium at ₹ 1100

- ◆ Doubt Support ◆ Advanced Level Test Access
- ◆ Live Test Paper Discussion ◆ Final Revision Exercises

Start Date: **07 Sept. 2020**

हमारा विश्वास... हर एक विद्यार्थी है खास

Sol. (1)

$$\begin{aligned} \text{pitch} &= V \cos 60^\circ, \quad T = \frac{V}{2} \frac{2\pi m}{eB} \\ &= 4 \times 10^5 \times \frac{1}{2} \times \frac{2\pi}{0.3} \left(\frac{m}{e} \right) \\ &= \frac{4\pi \times 10^5 \times 10^{-8}}{0.3} \\ &= \frac{4 \times 3.14 \times 10^{-3}}{3 \times 10^{-1}} \\ &\approx 4 \times 10^{-2} \text{ m} \\ &\approx 4 \text{ cm} \end{aligned}$$

Q.13 Two identical strings X and Z made of same material have tension T_x and T_z in them. If their fundamental frequencies are 450 Hz and 300 Hz, respectively, then the ratio T_x/T_z is :

- (1) 2.25 (2) 1.25 (3) 0.44 (4) 1.5

Sol. (1)

$$f = \frac{1}{2L} \sqrt{\frac{T}{\mu}}$$

given, $\mu_x = \mu_z$ & $L_x = L_z$ as identical

$$\therefore f \propto \sqrt{T}$$

$$\Rightarrow \frac{T_x}{T_z} = \frac{f_x^2}{f_z^2} = \left(\frac{450}{300} \right)^2 = \left(\frac{3}{2} \right)^2 = \frac{9}{4}$$

$$\frac{T_x}{T_y} = 2.25$$

Q.14 A uniform cylinder of mass M and radius R is to be pulled over a step of height a ($a < R$) by applying a force F at its centre 'O' perpendicular to the plane through the axes of the cylinder on the edge of the step (see figure). The minimum value of F required is

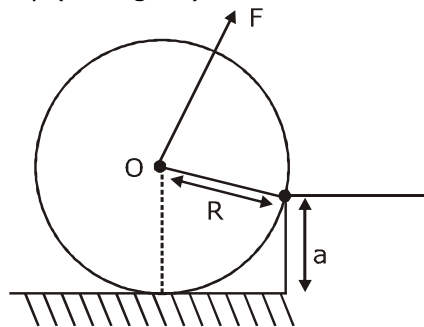

- (1) $Mg \sqrt{\left(\frac{R}{R-a} \right)^2 - 1}$ (2) $Mg \sqrt{1 - \frac{a^2}{R^2}}$ (3) $Mg \frac{a}{R}$ (4) $Mg \sqrt{1 - \left(\frac{R-a}{R} \right)^2}$

CRASH COURSE
FOR JEE ADVANCED 2020

FREE Online Lectures Available on YouTube

Go Premium at ₹ 1100

- ◆ Doubt Support
- ◆ Advanced Level Test Access
- ◆ Live Test Paper Discussion
- ◆ Final Revision Exercises

Start Date: **07 Sept. 2020**

Sol. (4)

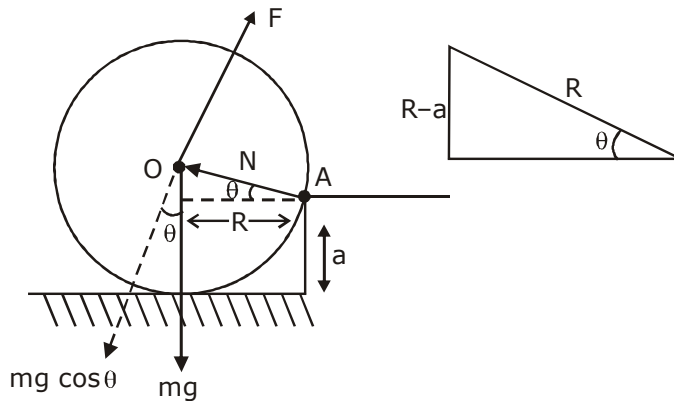

$$\cos \theta = \frac{\sqrt{R^2 - (R-a)^2}}{R}$$

$$= \sqrt{R^2 - \left(\frac{R-a}{R}\right)^2}$$

$$= \sqrt{1 - \left(\frac{R-a}{R}\right)^2}$$

to pull up, $\tau_F \geq \tau_{mg}$

$$FR \geq mg \cos \theta R$$

for min F, $F_{\min} = mg \cos \theta$

$$F_{\min} = mg \sqrt{1 - \left(\frac{R-a}{R}\right)^2}$$

CRASH COURSE
FOR JEE ADVANCED 2020

FREE Online Lectures Available on YouTube

Go Premium at ₹ 1100

◆ Doubt Support ◆ Advanced Level Test Access
◆ Live Test Paper Discussion ◆ Final Revision Exercises

Start Date: **07 Sept. 2020**

हमारा विश्वास... हर एक विद्यार्थी है खास

- Q.15** In a reactor, 2 kg of ${}_{92}\text{U}^{235}$ fuel is fully used up in 30 days. The energy released per fission is 200 MeV. Given that the Avogadro number, $N = 6.023 \times 10^{26}$ per kilo mole and $1 \text{ eV} = 1.6 \times 10^{-19} \text{ J}$. The power output of the reactor is close to
 (1) 60 MW (2) 54 MW (3) 125 MW (4) 35 MW

Sol. (1)

$$n(\text{moles}) = \frac{2\text{kg}}{235\text{gm}} = \frac{2000}{235}$$

$$\text{no. of nucleus} = N_A \times n$$

$$= 6.022 \times 10^{23} \times \frac{2000}{235}$$

$$= 51.25 \times 10^{23}$$

$$\text{total energy released} = 200 \times 51.25 \times 10^{23} \text{ MeV}$$

$$= 102.5 \times 10^{25} \text{ MeV}$$

$$= 102.5 \times 10^{25} \times 10^6 \times 1.6 \times 10^{-16} \text{ J}$$

$$= 164 \times 10^6 \text{ MJ}$$

$$\text{power} = \frac{164 \times 10^6 \text{ MJ}}{30 \times 24 \times 60 \times 60 \text{ S}}$$

$$= 0.063 \times 10^3 \text{ MW}$$

$$\cong 60 \text{ MW}$$

- Q.16** A charged particle (mass m and charge q) moves along X axis with velocity V_0 . When it passes through the origin it enters a region having uniform electric field $\vec{E} = -E\hat{j}$ which extends upto $x = d$. Equation of path of electron in the region $x > d$ is :

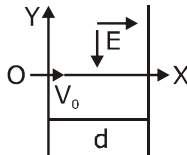

$$(1) y = \frac{qEd^2}{mV_0^2} x$$

$$(2) y = \frac{qEd}{mV_0^2} \left(\frac{d}{2} - x \right)$$

$$(3) y = \frac{qEd}{mV_0^2} (x - d)$$

$$(4) y = \frac{qEd}{mV_0^2} x$$

CRASH COURSE
FOR JEE ADVANCED 2020

FREE Online Lectures Available on **YouTube**

Go Premium at ₹ 1100

◆ Doubt Support ◆ Advanced Level Test Access
 ◆ Live Test Paper Discussion ◆ Final Revision Exercises

Start Date: **07 Sept. 2020**

Sol. (2)

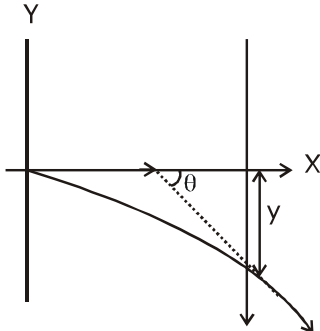

$$-y = \frac{1}{2} at^2$$

$$-y = \frac{1}{2} \frac{qE}{m} t^2 \quad \dots(1)$$

$$X = V_0 t$$

$$\Rightarrow t = \frac{x}{V_0} \quad \dots(2)$$

for $x \leq d$,

$$y = -\frac{1}{2} \frac{qE}{m} \frac{x^2}{V_0^2} \quad \dots(3)$$

$$\left. \frac{dy}{dx} \right|_{x=d} = -\frac{1}{2} \frac{qE}{m} \times \frac{2x}{V_0^2} \Big|_{x=d}$$

$$\text{Slope} = m = \tan \theta = -\frac{qEd}{mV_0^2}$$

equation of straight line,

$$y = (\tan \theta) x + c \quad \dots(4)$$

$$= -\left(\frac{qEd}{mV_0^2} \right) x + c$$

(now for C, at $x = d$, $Y = -\frac{qEd^2}{2mV_0^2}$ put in (4))

$$-\frac{qEd^2}{2mV_0^2} = -\frac{qEd^2}{mV_0^2} + c$$

CRASH COURSE
FOR JEE ADVANCED 2020

FREE Online Lectures Available on YouTube

Go Premium at ₹ 1100

◆ Doubt Support ◆ Advanced Level Test Access
◆ Live Test Paper Discussion ◆ Final Revision Exercises

Start Date: **07 Sept. 2020**

हमारा विश्वास... हर एक विद्यार्थी है खास

$$\Rightarrow c = \frac{qEd^2}{2mv_0^2}$$

for $x > d$, as no \vec{E}

$$y = -\left(\frac{qEd}{mv_0^2}\right)x + \frac{qEd^2}{2mv_0^2}$$

$$y = \frac{qEd}{mv_0^2} \left(\frac{d}{2} - x\right)$$

Q.17 Train A and train B are running on parallel tracks in the opposite directions with speeds of 36 km/hour and 72 km/hour, respectively. A person is walking in train A in the direction opposite to its motion with a speed of 1.8 km/hour. Speed (in ms^{-1}) of this person as observed from train B will be close to : (take the distance between the tracks as negligible)

- (1) 29.5 ms^{-1} (2) 30.5 ms^{-1} (3) 31.5 ms^{-1} (4) 28.5 ms^{-1}

Sol. (1)

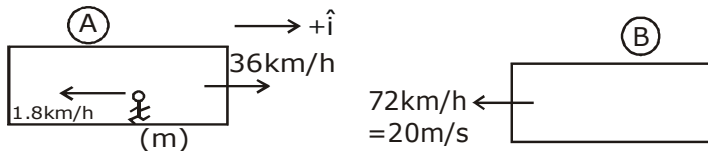

$$\vec{V}_m = \vec{V}_{m/A} + \vec{V}_A$$

$$= (-1.8 \hat{i} + 36 \hat{i}) \text{ km/h}$$

$$= \left(-1.8 \times \frac{5}{18} + 36 \times \frac{5}{18}\right) \text{ m/s}$$

$$= (-0.5 \hat{i} + 10 \hat{i}) \text{ m/s}$$

$$= 9.5 \hat{i} \text{ m/s}$$

$$\vec{V}_{m/B} = \vec{V}_m - \vec{V}_B$$

$$= 9.5 \hat{i} - (-20 \hat{i}) \text{ m/s}$$

$$= 29.5 \text{ m/s } \hat{i}$$

CRASH COURSE
FOR JEE ADVANCED 2020

FREE Online Lectures Available on [YouTube](#)

Go Premium at ₹ 1100

- ◆ Doubt Support ◆ Advanced Level Test Access
- ◆ Live Test Paper Discussion ◆ Final Revision Exercises

Start Date: **07 Sept. 2020**

- Q.18** Shown in the figure is rigid and uniform one meter long rod AB held in horizontal position by two strings tied to its ends and attached to the ceiling. The rod is of mass 'm' and has another weight of mass 2 m hung at a distance of 75 cm from A. The tension in the string at A is:

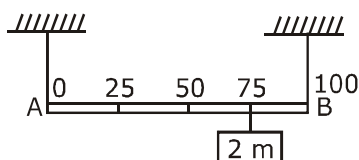

- (1) 0.75 mg (2) 0.5 mg (3) 1 mg (4) 2 mg

Sol. (3)

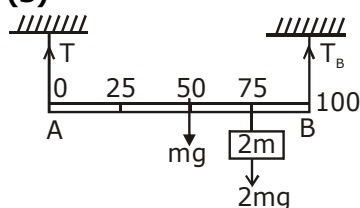

$$\tau_{\text{net}} \text{ about B} = 0$$

$$T \times 100\text{cm} = mg \times 50\text{cm} + 2mg \times 25\text{cm}$$

$$T = 1 \text{ mg}$$

- Q.19** The least count of the main scale of a vernier callipers is 1 mm. Its vernier scale is divided into 10 divisions and coincide with 9 divisions of the main scale. When jaws are touching each other, the 7th division of vernier scale coincides with a division of main scale and the zero of vernier scale is lying right side of the zero of main scale. When this vernier is used to measure length of a cylinder the zero of the vernier scale between 3.1 cm and 3.2 cm and 4th VSD coincides with a main scale division. The length of the cylinder is: (VSD is vernier scale division)

- (1) 3.21 cm (2) 3.07 cm (3) 2.99 cm (4) 3.2 cm

Sol. (2)

$$\text{L.C.} = 1\text{MSD} - 1\text{VSD}$$

$$\text{L.C.} = 0.1\text{MSD}$$

$$1 \text{ MSD} = 1\text{mm}$$

$$\text{L. C.} = 0.1\text{mm}$$

$$\begin{aligned} \text{+ve zero error} &= +7 \times \text{L.C.} \\ &= 0.7\text{mm} \end{aligned}$$

$$\begin{aligned} \text{Reading} &= (3.1\text{cm} + 4 \times \text{L.C.}) - \text{zero error} \\ &= 3.1\text{cm} + 0.4\text{mm} - 0.7\text{mm} \\ &= 3.1\text{cm} - 0.03\text{cm} \text{ (as given } 1 \text{ MSD} = 1\text{mm)} \\ &= 3.07 \text{ cm} \end{aligned}$$

हमारा विश्वास... हर एक विद्यार्थी है खास

Q. 20 A particle of mass m with an initial velocity $u\hat{i}$ collides perfectly elastically with a mass $3m$ at rest.

It moves with a velocity $v\hat{j}$ after collision, then v is given by:

(1) $v = \frac{1}{\sqrt{6}}u$

(2) $v = \sqrt{\frac{2}{3}}u$

(3) $v = \frac{u}{\sqrt{3}}$

(4) $v = \frac{u}{\sqrt{2}}$

Sol. (4)

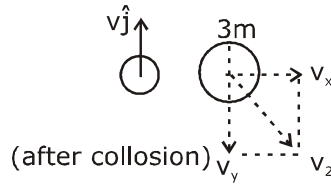
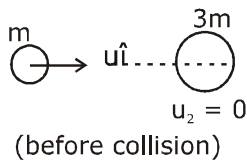

$$\vec{p}_i = \vec{p}_f$$

$$mu\hat{i} + 0 = mv\hat{j} + 3m\vec{V}_2$$

$$\frac{mu\hat{i}}{3m} - \frac{mv\hat{j}}{3m} = \vec{V}_2$$

$$\vec{V}_2 = \frac{u}{3}\hat{i} - \frac{v}{3}\hat{j}$$

now, K.E conserved as elastic collision

$$\Sigma KE_i = \Sigma KE_f$$

$$\frac{1}{2}mu^2 = \frac{1}{2}mv^2 + \frac{1}{2}3m\left(\frac{u^2}{9} + \frac{v^2}{9}\right)$$

$$\Rightarrow u^2 = v^2 + \frac{u^2}{3} + \frac{v^2}{3}$$

$$\frac{2}{3}u^2 = \frac{4}{3}v^2$$

$$\Rightarrow v = \frac{u}{\sqrt{2}}$$

CRASH COURSE
FOR JEE ADVANCED 2020

FREE Online Lectures Available on [YouTube](#)

Go Premium at ₹ 1100

◆ Doubt Support ◆ Advanced Level Test Access
◆ Live Test Paper Discussion ◆ Final Revision Exercises

Start Date: **07 Sept. 2020**

Q.21

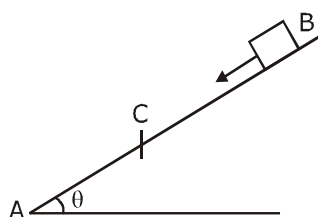

A small block starts slipping down from a point B on an inclined plane AB, which is making an angle θ with the horizontal section BC is smooth and the remaining section CA is rough with a coefficient of friction μ . It is found that the block comes to rest as it reaches the bottom (point A) of the inclined plane. If $BC = 2AC$, the coefficient of friction is given by $\mu = k \tan \theta$. The value of k is _____.

Sol. (3)

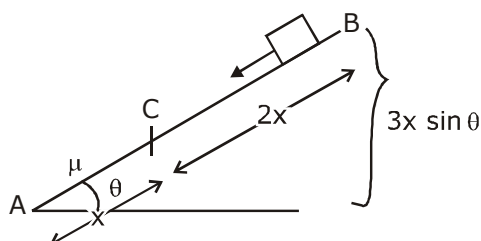

from work energy theorem

$$W_g + W_f = \Delta KE$$

$$mg \cdot 3x \sin \theta - \mu mg \cos \theta \cdot x = 0 - 0$$

$$\Rightarrow mg \cdot 3x \sin \theta = \mu mg \cos \theta \cdot x$$

$$3 \tan \theta = \mu$$

$$k = 3$$

Q.22 An engine takes in 5 moles of air at 20°C and 1atm, and compresses it adiabatically to $1/10^{\text{th}}$ of the original volume. Assuming air to be a diatomic ideal gas made up of rigid molecules, the change in its internal energy during this process comes out to be X kJ. The value of X to the nearest integer is _____.

Sol. (46)

$$T_2 V_2^{\gamma-1} = T_1 V_1^{\gamma-1}$$

$$T_2 = T_1 \left(\frac{V_1}{V_2} \right)^{\gamma-1}$$

$$= 293 \left(\frac{V}{V/10} \right)^{7/5-1}$$

$$T_2 = 293 \times (10)^{2/5}$$

$$\Delta U = n C_v \Delta T = 5 \times \frac{5}{2} R \left(293 \times 10^{2/5} - 293 \right)$$

CRASH COURSE
FOR JEE ADVANCED 2020

FREE Online Lectures Available on YouTube

Go Premium at ₹ 1100

◆ Doubt Support ◆ Advanced Level Test Access
◆ Live Test Paper Discussion ◆ Final Revision Exercises

Start Date: **07 Sept. 2020**

हमारा विश्वास... हर एक विद्यार्थी है खास

$$= \frac{25}{2} R \times 293 \left(10^{\frac{2}{5}} - 1 \right) = \frac{25R}{2} \times 293(2.5 - 1)$$

$$= \frac{25 \times 8.314 \times 293 \times 1.5}{2}$$

$$= 45675 \text{ J} = 46 \text{ kJ}$$

Q.23 When radiation of wavelength λ is used to illuminate a metallic surface, the stopping potential is V .

When the same surface is illuminated with radiation of wavelength 3λ , the stopping potential is $\frac{V}{4}$.

If the threshold wavelength for the metallic surface is $n\lambda$ then value of n will be _____.

Sol. (9)

$$\frac{hc}{\lambda} = \phi + eV \quad \dots(1)$$

$$\frac{hc}{3\lambda} = \phi + \frac{eV}{4} \quad \dots(2)$$

$$\frac{\text{eq. (1)}}{\text{eq. (2)}} \quad 3 = \frac{\phi + eV}{\phi + \frac{eV}{4}}$$

$$3\phi + \frac{3eV}{4} = \phi + eV$$

$$2\phi = \frac{eV}{4}$$

$$\phi = \frac{eV}{8}$$

$$\frac{hc}{\lambda} = \frac{eV}{8} + eV$$

$$= \frac{9}{8} eV$$

$$\therefore eV = \frac{8}{9} \frac{hc}{\lambda}$$

$$\text{so } \phi = \frac{hc}{\lambda} - \frac{8}{9} \frac{hc}{\lambda}$$

$$\phi = \frac{1}{9} \frac{hc}{\lambda}$$

$$\frac{hc}{\lambda_{\text{th}}} = \frac{hc}{9\lambda}$$

$$\therefore \lambda_{\text{th}} = 9\lambda$$

CRASH COURSE
FOR JEE ADVANCED 2020

FREE Online Lectures Available on  YouTube

Go Premium at ₹ 1100

◆ Doubt Support ◆ Advanced Level Test Access
◆ Live Test Paper Discussion ◆ Final Revision Exercises

Start Date: **07 Sept. 2020**

Q.24 A circular coil of radius 10 cm is placed in uniform magnetic field of 3.0×10^{-5} T with its plane perpendicular to the field initially. It is rotated at constant angular speed about an axis along the diameter of coil and perpendicular to magnetic field so that it undergoes half of rotation in 0.2s. The maximum value of EMF induced (in μV) in the coil will be close to the integer _____.

Sol. (15)

$$\phi = BA \cos \omega t$$

$$E = \frac{-d\phi}{dt} = BA\omega \sin \omega t$$

$$E_{\max} = BA \omega \quad \left(\omega = \frac{\pi}{0.2} \right)$$

$$= 3 \times 10^{-5} \times \pi R^2 \times \frac{\pi}{0.2}$$

$$= 15 \times 10^{-6} \text{ V}$$

$$= 15 \mu\text{V}$$

Q.25 A $5\mu\text{F}$ capacitor is charged fully by a 220V supply. It is then disconnected from the supply and is connected in series to another uncharged $2.5 \mu\text{F}$ capacitor. If the energy change during the charge redistribution is $\frac{X}{100}$ J then value of X to the nearest integer is _____.

Sol. (40) Our Answer

NTA Answer 36

$$\text{heat} = U_i - U_f$$

$$= \frac{1}{2} \frac{C_1 C_2}{C_1 + C_2} (V_1 - V_2)^2$$

$$= \frac{1}{2} \frac{5 \times 2.5}{7.5} (220 - 0)^2$$

$$= \frac{5}{6} \times 220 \times 220 \times 10^{-6} \text{ J}$$

$$= 40,333.33 \times 10^{-6} \text{ J}$$

$$\frac{x}{100} = 0.4 \text{ J}$$

$$x = 40$$

CRASH COURSE
FOR JEE ADVANCED 2020

FREE Online Lectures Available on YouTube

Go Premium at ₹ 1100

◆ Doubt Support ◆ Advanced Level Test Access
◆ Live Test Paper Discussion ◆ Final Revision Exercises

Start Date: **07 Sept. 2020**

जब इन्होंने पूरा किया अपना सपना
तो आप भी पा सकते है लक्ष्य अपना

Admission
OPEN

JEE MAIN RESULT 2019



Nitin Gupta

Marks
335
13th (2019)

Marks
149
12th (2018)



Shiv Modi

Marks
318
13th (2019)

Marks
153
12th (2018)



Ritik Bansal

Marks
308
13th (2019)

Marks
218
12th (2018)



Shubham Kumar

Marks
300
13th (2019)

Marks
153
12th (2018)

KOTA'S PIONEER IN DIGITAL EDUCATION

1,95,00,000+ viewers | **72,67,900+** viewing hours | **2,11,000+** Subscribers

SERVICES	SILVER	GOLD	PLATINUM
Classroom Lectures (VOD)			
Live interaction	NA		
Doubt Support	NA		
Academic & Technical Support	NA		
Complete access to all content	NA		
Classroom Study Material	NA		
Exercise Sheets	NA		
Recorded Video Solutions	NA		
Online Test Series	NA		
Revision Material	NA		
Upgrade to Regular Classroom program	Chargeable	Chargeable	Free
Physical Classroom	NA	NA	
Computer Based Test	NA	NA	
Student Performance Report	NA	NA	
Workshop & Camp	NA	NA	
Motion Solution Lab- Supervised learning and instant doubt clearance	NA	NA	
Personalised guidance and mentoring	NA	NA	

FEE STRUCTURE

CLASS	SILVER	GOLD	PLATINUM
7th/8th	FREE	₹ 12,000	₹ 35,000
9th/10th	FREE	₹ 15,000	₹ 40,000
11th	FREE	₹ 29,999	₹ 49,999
12th	FREE	₹ 39,999	₹ 54,999
12th Pass	FREE	₹ 39,999	₹ 59,999

+ Student Kit will be provided at extra cost to Platinum Student.

- * **SILVER (Trial)** Only valid 7 DAYS or First 10 Hour's Lectures.
- ** **GOLD (Online)** can be converted to regular classroom (Any MOTION Center) by paying difference amount after lockdown.
- *** **PLATINUM (Online + Regular)** can be converted to regular classroom (Any MOTION Center) without any cost after lockdown.

New Batch Starting from :
16 & 23 September 2020

Zero Cost EMI Available

MOTION™

H.O. : 394, Rajeev Gandhi Nagar, Kota
www.motion.ac.in | ✉ : info@motion.ac.in